

## PRODUCT DATA SHEET

# Type 7 Belt Meter

The **Type 7 Belt Meter** is suitable for measuring frequencies in all types of power transmission belts, ranging from toothed timing belts to poly-vee belts.

The belt meter is **available as an Optical and Acoustic** has a frequency measurement range is from **10Hz to 600Hz**.

The Type 7 belt meter has the function to operate in **Newtons (N)** and **Pounds (Lbs)** as well as Hertz (Hz). The Newtons and Pounds values is calculated from the belt span and belt mass data, which is entered into the meter. Up to 3 sets of data may be stored in the meter for easy recall. The display may be changed from Hertz, Newtons, and Pounds by the press of a single key.

Based upon the measured belt frequency, the meter can calculate belt tensions up to **9,990 N (2,200 lbs)**.



### Optical

The **Type 7 Optical** has a frequency measurement range of **10Hz to 600Hz** and uses an optical sensor head. This meter is useful where there is a requirement to measure tension in a variety of belts, some vibrating at low frequencies.

The optical sensor head uses an infrared beam to detect the vibration of the belt. It is particularly suitable for small belts under low levels of tension. This meter is useful for wide belts with large spans.

The belt must be tapped to induce the natural frequency of vibration. The sensor may be beamed onto the flat side of the belt (either the outer faces or pulley contact face) from distances of 5-15mm although in most cases readings may be taken from distances up to 50mm. Alternatively, the edge of the belt may be used, with the depth finger on the sensor head providing an easy way to hold the sensor steady.



### Acoustic

The acoustic sensor uses a Clavis patented technique for detecting the belt vibration signal whilst minimising ambient noise. The acoustic sensor is particularly suitable for belts which vibrate poorly or where the amplitude of belt vibration is very small. The 'jaws' of the sensor should be positioned over the centre of the belt and placed mid length of the belt span. The sensor should not be allowed to touch the belt as this will reduce the belt vibration signal. A range of sensors are available to suit belts of differing widths.



### Serial (RS-232) Communication

Each time a reading is taken the value is transmitted through the RS232 serial port. The following protocol is employed; Baud Rate 9600, 8 data bits, 1 stop bit. The value string is terminated by a 'CR', (Decimal 13). Output is through a 9-way D' type plug, (Pin 5 common, Pin 3 Transmit). Handshaking is not employed.

Rechargeable batteries provide 30 hours of continuous operation. Automatic power off occurs 2 minutes from the last use of the meter.

Every Clavis meter is supplied with a precision mechanical resonator (tuning fork) for simple calibration validation by the user. If you have additional calibration requirements Clavis can supply a Sonic Calibration Meter.

### You can expect each device to have the following;

- Clavis Patented Sensor
- Carrying Case
- Tuning Fork (*Calibration Check*)
- Calibration Certification
- Battery Charger
- Rechargeable Batteries



PRODUCT DATA SHEET

Type 7 Belt Meter

TECHNICAL SPECIFICATION

Measurement Range	
Frequency Range (Acoustic)	30Hz to 600Hz
Frequency Range (Optical)	10Hz to 600Hz
Measurement Accuracy	
Below 100Hz	+/- 1 significant digit
Above 100Hz	+/- 1%
Environment Conditions	
Operating Temperature	+10°C to +50°C +50°F to +122°F
Shipment & Storage Temperature	+5°C to +70°C +23°F to +158°F
Protection Class	IP54
Sensor (Acoustic)	
Type	Standard Type 3 (Different types available)
Belt Size	Belts up to 25mm wide
Entry	Rear/Top
Housing	Cast aluminium
Sensor (Optical)	
Type	Infrared Optical
IR Wavelength	970nm
Visible Aiming Beam	Narrow angle orange LED
Housing	Machined aluminium
Cable length	1m
Power Supply	
Battery Type	AA (1.5V) Alkaline
Number	(Optional rechargeable - see below)
Expected life	4
Compartment Location	20 hrs Back of meter
Optional Rechargeable Batteries	
Battery Type	AA (1300 mAh minimum)
Charger	12 to 15 V DC output
Socket/polarity	3.5mm positive centre

DIMENSIONS

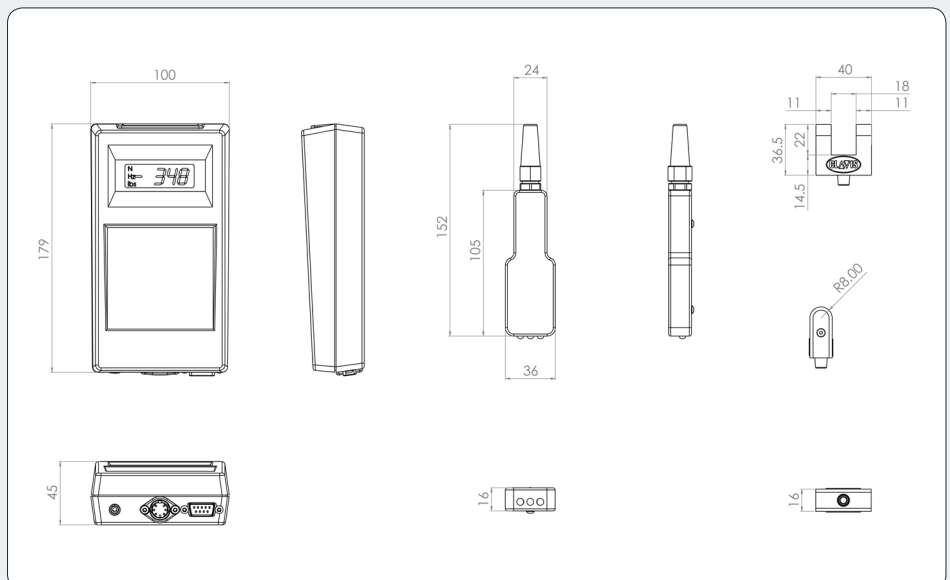

IDS INTEGRATED DISPLAY SYSTEMS LTD

Unit 4A New York Way  
New York Industrial Park  
Newcastle upon Tyne  
NE27 0QF, UK

admin@clavis.co.uk  
t: + 44 (0) 191 262 7869

www.clavis.co.uk